



## **BUSINESS PLAN**

### **ISO/TC 266 Biomimetics**

#### **EXECUTIVE SUMMARY**

Biomimetics combine the disciplines of biology and technology or other fields of innovation with the goal of solving practical problems through the abstraction, transfer, and application of knowledge gained from biological systems by interdisciplinary cooperation. This can give rise to many new innovations which in the past have often proved to be sustainable and economically efficient. Therefore, an increasing number of products, processes, patents and related events have evolved especially since the year 2000.

Despite this success not all products derived from such approaches are made visible and vice versa. Occasionally, the terms “bionic” or “biomimetic” are used for products where no biomimetic approach can be found. This uncertainty needs to be resolved for legal as well as quality assurance aspects.

Standards are expected to contribute to the overall acceptance of biomimetic new or optimized products. Such products have potential to boost important aspects such as sustainability, business opportunities or legal issues, all for the benefit of the product’s producers and their respective customers. In this context sustainability is leveraged due to increased environmental compatibility as a result of reduced resource consumption and emissions. If these benefits are widely accepted through the means of standards, then companies may find easier access to new products and new markets based on these products and can thus derive appropriate long-term business strategies. It goes without saying that standards for biomimetics also help both, producers as well as consumers of biomimetic products, to rely on a legal foundation e.g. in regards to product liability. In cases where no products but methods are involved, standards give rise to clear distinction of what biomimetics includes and what it does not include. Moreover, it is expected that standards in biomimetics help to prepare for the next technological leap.

Objectives of the ISO/TC are the development of international standards regarding terminology, advanced materials and biomimetic optimization. In this context, terminology is standardized for clear distinction between biomimetic and conventional products and processes. Additional standards are concerned with biomimetic methods, structures and materials describing the transfer of biological principles into technical applications. Further standards include biomimetic structure optimization.

Further standards might be developed in the future.

## 1 INTRODUCTION

### 1.1 ISO technical committees and business planning

The extension of formal business planning to ISO Technical Committees (ISO/TCs) is an important measure which forms part of a major review of business. The aim is to align the ISO work program with expressed business environment needs and trends and to allow ISO/TCs to prioritize among different projects, to identify the benefits expected from the availability of International Standards, and to ensure adequate resources for projects throughout their development.

### 1.2 International standardization and the role of ISO

The foremost aim of international standardization is to facilitate the exchange of goods and services through the elimination of technical barriers to trade.

Three bodies are responsible for the planning, development and adoption of International Standards: [ISO](#) (International Organization for Standardization) is responsible for all sectors excluding Electrotechnical, which is the responsibility of [IEC](#) (International Electrotechnical Committee), and most of the Telecommunications Technologies, which are largely the responsibility of [ITU](#) (International Telecommunication Union).

ISO is a legal association, the members of which are the National Standards Bodies (NSBs) of some 140 countries (organizations representing social and economic interests at the international level), supported by a Central Secretariat based in Geneva, Switzerland.

The principal deliverable of ISO is the [International Standard](#).

An International Standard embodies the essential principles of global openness and transparency, consensus and technical coherence. These are safeguarded through its development in an ISO Technical Committee (ISO/TC), representative of all interested parties, supported by a public comment phase (the ISO Technical Enquiry). ISO and its [Technical Committees](#) are also able to offer the ISO Technical Specification (ISO/TS), the ISO Public Available Specification (ISO/PAS) and the ISO Technical Report (ISO/TR) as solutions to market needs. These ISO products represent lower levels of consensus and have therefore not the same status as an International Standard.

ISO offers also the International Workshop Agreement (IWA) as a deliverable which aims to bridge the gap between the activities of consortia and the formal process of standardization represented by ISO and its national members. An important distinction is that the IWA is developed by ISO workshops and fora, comprising only participants with direct interest, and so it is not accorded the status of an International Standard.

## 2 BUSINESS ENVIRONMENT OF THE ISO/TC

### 2.1 Description of the Business Environment

The following political, economic, technical, regulatory, legal and social dynamics describe the business environment of the industry sector, products, materials, disciplines or practices related to the scope of this ISO/TC, and they may significantly influence how the relevant standards development processes are conducted and the content of the resulting standards.

Innovations in biomimetics such as biomimetic materials with various characteristics and performances and biomimetic processes are becoming of increasing interest in many fields of practical applications. In contrast to human-made materials, natural materials such as wood, bone and shells are composed of only a limited number of basic components. They gain their diversity in mechanical properties by hierarchical structuring which allows them to fulfil a variety of functions e.g. self-healing, resilience, mechanical stability, high toughness. In addition, biogenic materials and structures grow and develop at ambient conditions, making them low-energetic solutions that outperform the majority of established technologies.

As a result of quickly advancing physical characterization techniques, knowledge about hierarchical structures has increased significantly in recent years and form-function relationships are being unveiled. But combining the knowledge about natural materials with modern techniques of simulation and fabrication is still the exception, also due to the lack of communication between natural scientists as well as engineers of various fields.

Aiming at a common language for scientists and engineers working in the field of biomimetics, the first published standard ISO 18458 was on definitions, terminology and differentiation between biomimetic and conventional methods and products.

#### **State of the art:**

Biomimetics combine the disciplines of biology and technology or other fields of innovation with the goal of solving practical problems through the abstraction, transfer, and application of knowledge gained from biological systems by interdisciplinary cooperation. Biomimetics is not limited to any specific research area. Developments inspired by nature can be found in all areas of life and industrial production starting with clothing (e.g. non-wettable textiles) to automotive applications (e.g. nature inspired ergonomic seats, biomimetic wheel rim or optimized load-bearing components) as far as applications in medical technology (e.g. orthopedic implants, prostheses or wound pads).

One of the most important drivers in biomimetic innovation is the approach in generating new unexpected processes and products. These innovations have the potential to be sustainable. Due to the strong connection to biodiversity (need of biological systems and use of natural processes) the potential is enormous. The innovation process in biomimetics can continue beyond the singular abstraction and application of a natural principle. For example the invention of the Lotus Effect<sup>®</sup> created at least 200 side innovations. The flectofin<sup>®</sup> facade shades built after the principle of a bending mechanism in the Strelizia flower have been developed further using conventional techniques. Hence, biomimetics has the potential for a large variety of innovative products, making biomimetics an economically very efficient approach.

#### **Dynamics:**

**Economic:** Biomimetics has an impact on nearly all industry branches and has intersections with many research areas (e.g., nanotechnology, material sciences, surface performance, robotics, automation, sensor technology, medical engineering etc.). In various industrial processes and products biomimetics is increasingly accepted and applied. Since the year 2000 a rapid boost of products, patents, publications and events occurred.

**Technical:** Biomimetics is not only a creativity technique to create new ideas for production but a method for new innovation processes useful in almost all research areas and industries. Due to the inherent interdisciplinary work between natural scientists, engineers and technicians biomimetics can also be understood as a new general approach for team-building and cooperation that is necessary in most innovative product development.

**Regulatory:** The biomimetic origin of applications in final products is often not visible and manufacturers do not promote the use of biomimetic components or products. For example, almost all car manufacturers integrate components that have been optimized with biomimetic methods. On the other hand the term “bionic” or “biomimetic” is used for promotion of products where no biomimetic approach can be found. Standards in biomimetics will give legal certainty and considerations for quality assurance in deciding whether there is a biomimetic product or not. Additionally, they can build a common ground for also governmental/political initiatives that focus on using natural principles for innovation. Furthermore inspiration by nature has a strong reference to the EU’s biodiversity policy and strategy. It is obvious that the source for inspiration needs to be protected and conserved.

**Societal:** Biomimetics has per se a positive connotation. It combines nature with technology and therefore can be used as a role model for the so called MINT subjects (mathematics, information technology, natural sciences and engineering). Media interest is high and is a mixture of the novel science and potential benefits with concerns for environmental issues. Biomimetics has an inherent close link to nature and biodiversity. Understanding natural processes supports the public willingness to conserve nature and biodiversity.

**International:** Innovation and commercialization through Biomimetics is a global challenge. International collaboration is growing with the knowledge that no single country can fund the research and development necessary for the effective adoption of biomimetic processes and products. International standards for biomimetics are required to prevent technical barriers and lay the foundations for an efficient interdisciplinary cooperation in science and engineering and with all connected industry branches.

#### **Stakeholder and initiatives:**

The worldwide interest in biomimetic processes and products is growing. The interested parties (the stakeholders) in biomimetics as well as in standards on biomimetics to be elaborated by ISO/TC 266 are, i.e.:

- Various industry sectors (e.g. automotive, energy, aerospace, civil engineering, architecture, design)
- Various manufacturers (e.g. of building products, transportation systems)
- Government and ministries (e.g. of trade and industry, transport, energy, environment, research)
- Universities, research centers, private/industrial/public development departments
- NGOs (e.g. national and international associations of trade and industry, transport, energy, environment, research)
- Consumers' associations

These stakeholders are often united in national or international networks. Therefore, in various countries scientific and enterprise networks in biomimetics have been established or will be established within the next year. The networks concentrate expertise from different fields in the biological, natural, and engineering sciences, and increasingly from business, in various ways and at various levels. They represent the interests of the scientist and developers involved in biomimetics, increase the visibility of biomimetic projects and products, and accelerate and increase the transfer of know-how from universities and extramural research institutions into industrial applications.

A number of events are held, for example conventions, symposiums, workshops, and seminars [e.g. the International Industrial Convention on Biomimetics ([www.biomimetics-convention.com](http://www.biomimetics-convention.com)), the biomimetics Business Forum ([www.bionik-wirtschaftsforum.de](http://www.bionik-wirtschaftsforum.de)), as well as the “biomimetics: Patents from Nature” convention ([www.bionik.hs-bremen.de](http://www.bionik.hs-bremen.de))].

Some universities offer full-time degree programs in biomimetics (bachelor and master programs) or courses of study in biomimetics. Furthermore, there are numerous modular educational programs offered in the form of seminars, lecture series, or specialized courses at the university level. In addition, postgraduate and professional education programs in the context of lifelong learning have been developed and offered.

Educational materials for schools are currently under active development. Furthermore, biomimetics can be a highly promising, integrative learning method, especially in grade schools and preschool education where interdisciplinary forms of learning have already been established. For the integration of biomimetics into professional education, it is necessary to implement it in the corresponding training plans. This requires cooperation with the providers of professional education programs (vocational schools and academies, chambers of commerce and industry). The same also applies to the wide field of professional training in the context of lifelong learning.

Biomimetics is already a widely used research and development approach in the area of extramural research.

## **2.2 Quantitative Indicators of the Business Environment**

The following list of quantitative indicators describes the business environment in order to provide adequate information to support actions of the ISO/TC 266. This list is not exhaustive:

### **Examples for application in industrial sectors**

- Automotive (e.g., lightweight construction, sensor technology, ergonomic design)
- Textile (e.g., Lotus-Effect<sup>®</sup>, light interferences)
- Automation technology (e.g., lightweight material, robotics, sensors)
- Building and construction (e.g., Lotus-Effect<sup>®</sup>-paints, insulation systems, lightweight construction, facade shades, design, self-healing materials)
- Aviation and aerospace industry (e.g., friction reduced surfaces, lightweight construction, self-healing materials)
- Medical engineering (e.g., robotic, adhesion, Fin Ray<sup>®</sup>, wound pads, prosthetics)

### **Products and materials**

Starting in 1948 by developing Velcro<sup>®</sup> biomimetic developments and biomimetic products are established in many different sectors during the last decades.

#### **Materials**

Self-sharpening cutting tools based on rodents' teeth improve the applicability of tool kits and instruments with regard to durability and stability.

Concrete is the one of the most popular construction materials. However, it is quite vulnerable to cracking because of its inherent heterogeneity, low tensile strength and the non-ideal service environment. Although reinforced concrete is designed to crack (with limited crack widths) and the cracks do not pose structural problems, these cracks provide an easy path for water and other aggressive substances to penetrate inside the concrete matrix and may impair the long term durability. Therefore, the self-healing properties of biological materials are mimicked to obtain autonomous healing of cracks. Healing agents are incorporated into the concrete matrix during casting. When cracks appear, healing agents will be released from within the concrete and flow into cracks to seal the cracks from the inside. Also other materials such as polymers, composites, coatings, ceramics, etc. can be designed to be self-healing. The concept of self-healing is becoming increasingly important because of the economic and environmental cost of obsolescence.

Lightweight construction and other structures can benefit from the so-called "technical plant stem", a biomimetic fiber-based composite material inspired by winter horsetail (*Equisetum hyemale*) and giant reed (*Arundo donax*). It is characterized by a high level of bending stiffness, an extremely high dynamic load capacity and damping behavior and can therefore be used for many applications, including aerospace technology, vehicle construction, building and civil engineering, machinery and equipment construction, medical technology (prosthetics) and sports equipment, etc.

The Fin Ray<sup>®</sup> effect based on fish fins is used e.g. for shape adaptive grippers and ergonomic seat backs.

Heat loss is prevented through the isolating property of the air trapped between the fibers.

### Surfaces

There are over 200 patents dealing with the Lotus-Effect<sup>®</sup> and numerous practical applications include self-cleaning exterior paints, render finishes, and roof tiles.

Surface structures with reduced frictional resistance in connection with self-cleaning surface structures can be used e.g. for the hulls of ships and aircrafts in order to reduce fuel consumption and cleaning agents. In plastic injection molding processes this effect is used for molds with self-cleaning surfaces.

Unlike the skin of whales and manatees, shark skin doesn't pick up algae or barnacles. This seems to be due to little scales called "dermal denticles." Sharklet is an engineered surface that, through pattern alone, inhibits bacterial growth. The company, Sharklet Technologies, Inc., sells adhesive-backed films for covering surfaces and manufactures the pattern into medical devices like urinary catheters.

Adhesive materials based on the principle of reversible insect or gecko adhesion to plain surfaces are used for reverse conjunctions.

Optical effects and light interferences due to nano- and micro structure promote new design, fashion and marketing products

### Optimization

Optimization software: Computer simulations such as the CAO (computer aided optimization) and SKO (soft kill option) methods are used for lightweight constructions resulting in considerable material savings, reduced fuel consumption as well as unconventional design.

Optimized tires and wheel rims show an important impact for road safety as well as considerable material savings.

Optimized propeller design based on vortexes created by bird's wing reduces noise and fuel consumption.

In order to reduce noise emissions of high speed trains, engineers abstracted the bills of kingfishers, which can dive into water with scarcely a splash. Kingfishers wedge themselves into water with a streamlined beak that gradually increases in diameter from tip to head, letting water flow past. By modeling bullet train noses on kingfisher beaks, Japanese engineers created the 500 series of the Shinkansen, which entered service in 1997. The trains are quieter, 10 percent faster and use 15 percent less electricity.

### Robotic

Applications for biomimetic robots can be found, e.g. in safe man-machinery interaction. The natural model in this case is the elephant's trunk. Robots using biomimetic muscles can be introduced in working surroundings not tolerable or safe for humans.

### Sensor technology

Active tactile sensors abstracted from insects enable contactless distance measurement and safety handling e.g. in sensitive application fields.

Biological sensors are characterized by exactness, velocity and selectivity. The transfer to technical applications is just at the beginning and show large potential for the future. They are already used e.g. for electronic nose or underwater acoustic modems using self-adaptive algorithms.

### Architecture

As an example of building technology façade shade systems based on Strelizia flowers show large potential for the construction of completely new building designs.

Another example related to structural engineering is the Eastgate Shopping Center and office block in Harare, Zimbabwe, for which the structure of termite mounds was studied. The inside of a termite mound stays at near-constant temperature and humidity, no matter the conditions outside. Today, Eastgate uses 10 % of the energy required by similar conventional buildings, allowing also the rental rates to be lower.

### Other application ranges

Other methods of optimization, such as evolutionary algorithms, can also be dealt with. Other fields of application such as agriculture, chemistry, energy, organizational management issues, industrial ecology and social sciences are partly established or are under development. Biomimetic concepts and principles nowadays also might affect the structure of markets, organizations and modes of cooperation.

In summary, this multitude and diversity of biomimetic products and their various application possibilities show the big potential and the large influence of recent and future biomimetic developments.

## **Patents**

Generally, the mean numbers of patents filed per year was continuous over the past years with a steady rise of patents. The number of granted patents has an average of more than 1000 patents per year in the years 2010-2015 and the trend on the development of patent growth is increasing (Lenau et al., 2018).

## Biomimetics

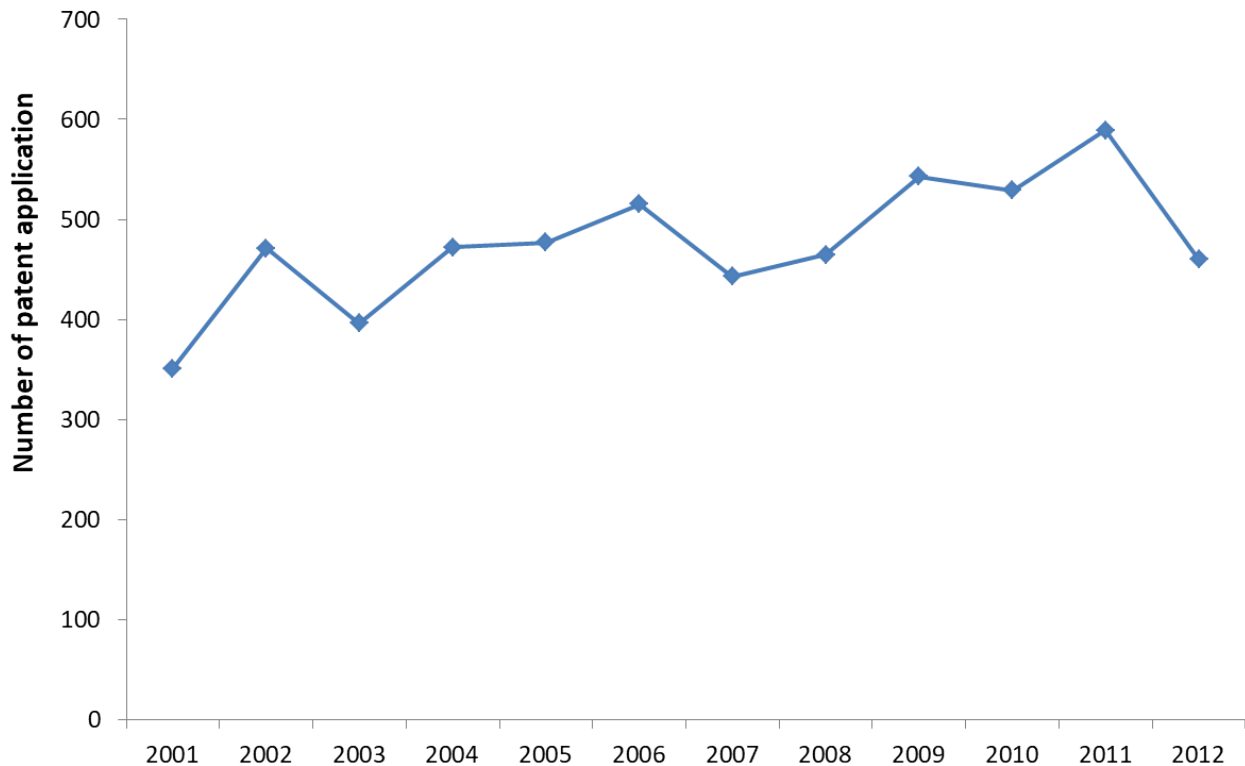

**Fig. 1: Patents filed per year in JP, US, EU, CH, KR and Other**  
 [source: Japan Patent Office (JPO) (2015), The Reports on Patent Application Trends: Biomimetics]

### Literature

The list of literature on biomimetics is constantly growing with an increasing number of publications per year. In 2013, Biomimetics led to nearly 3000 publications per year, which indicates a rapid growth over the last 15 years (Lepora et al., 2013) and this trend is still ongoing (Lenau et al., 2018). To give only one example of the numbers of publications on behalf of one specific topic the following Figure 2 is given. It shows contributions to the Second International Conference on Self-Healing Materials (2009), where a rough estimate of the amount of people, collaborating on a ‘Self-Healing Program’, have been made. Distinctions have been made between the different material classes and the different countries.

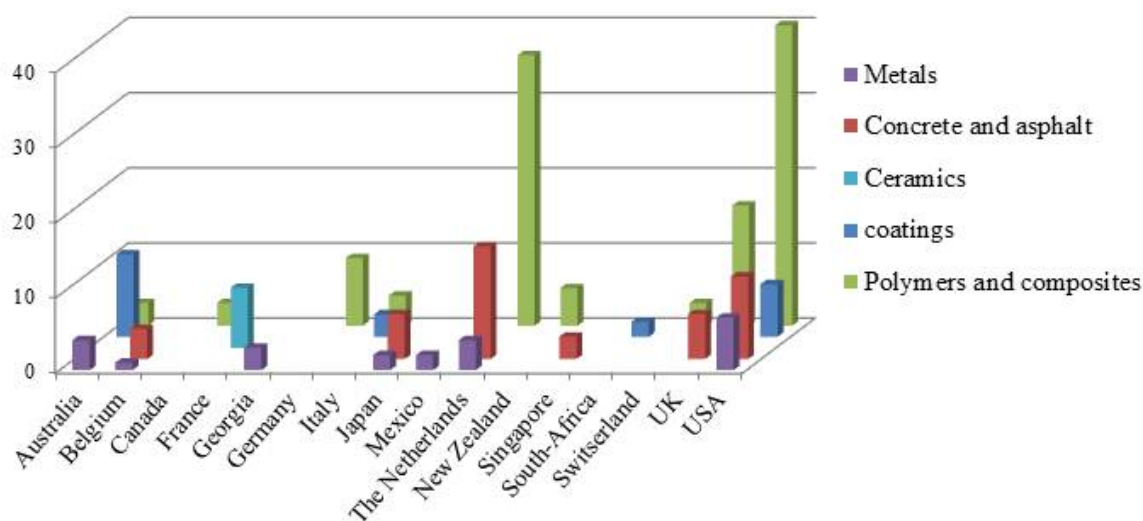

**Fig. 2: Contributions to the Second Intern. Conf. on Self-Healing Materials (Chicago, 2009)**

### **Economy**

Up to now revenue data is difficult to assess for specific countries or industries. However, there is a study available from the San Diego Zoological Society (Global Biomimicry efforts, An Economic Game Changer) which states that over the next 15 years, biomimicry-based goods and services could account for approximately \$300 billion of U.S. gross domestic product (GDP) by 2025. To put this figure in perspective, in 2010 U.S. companies have spent an estimated \$282 billion on computer software. While initially small relative to a total U.S. economy that is estimated to generate approximately \$21 trillion of goods and services in 2025, biomimicry will still have a highly significant impact that can be expected to continue to grow rapidly as knowledge and the field expand.

The same study claims that biomimicry could also spread rapidly on a global scale. Assuming a smaller GDP share of 1.0% than the 1.4% calculated for the U.S. (with lesser shares among less technically advanced nations), biomimicry could affect about \$1.0 trillion of the world's total output by 2025.

## **3 BENEFITS EXPECTED FROM THE WORK OF THE ISO/TC**

### **Sustainability:**

Biomimetic product design is often employed to benefit from product improvement. This may span increase of functionality, resource efficiency or product life as well as decrease of energy consumption, emissions or cost among a number of other reasons. ISO/TC 266 will explore the requirements of ISO Guide 82 and include them in the future.

### **Academia:**

Biomimetics is based on interdisciplinary cooperation and networking. The mutual scientific exchange will promote research and innovation. Standards in biomimetics give academia a common language and terminology for education and collaboration on research. This would allow biomimetics to be incorporated as a standard design approach.

**Business:**

Biomimetics can act as an innovation engine that pushes the economy and has impact on businesses. Standardization will give businesses tools for developing biomimetic strategies for new products, resulting in an expanded product development portfolio and new products for the market. Standards as a language of technology are understood and accepted in countless branches of industry. Outlining results in standards strengthens confidence in biomimetics, therefore, making it easier to close the gap between research and commercialization efforts. In industrial environments quality assurance of products and processes is of high significance to which standards in biomimetics will greatly contribute by providing mutual acceptance. Standards also play an important role for the efficient fulfillment of due diligence requirements needed in business relationships.

The development of ISO-standards in biomimetics makes it easier to establish references between basic design standards in certain fields and suitable biomimetic processes. This allows industries to integrate biomimetic methods into their product and process design routes without having to fear non-acceptance by customers. Synergies can be expected in product development – even in international teams from different stakeholders such as industry and/or research institutions – when unified standards are applied throughout the complete product life cycle from first drafts to choice of materials and resources to manufacturing to recycling and waste management.

**Customers/Products:**

Biomimetic products can be potentially more sustainable and more environmentally compatible than conventional ones. This, however, depends strongly on effective implementation of reduced resource consumption and emissions, e.g. by means of manifold types of optimization or lightweight design. In order to analyze aspects relevant to sustainability individual case studies of each biomimetic product are necessary. Furthermore, biomimetics can help create new products or even new technology fields from bottom up. Standards will contribute to the overall acceptance of biomimetic new or optimized products.

**Legal aspects:**

Standardization will help increase the acceptance of biomimetic products and approaches such that a wider recognition of the field not only among experts is expected. Hence, customers can be sure that products advertised as biomimetic are indeed such. In legal proceedings, it will be possible to determine whether a product or parts thereof can be deemed "biomimetic" and when not. Other ISO-TCs can benefit from standards in biomimetics by cross-referencing rules and recommendations for use in other standards and for clear separation of biomimetics from other topics.

**Summary:**

The identification of suitable underlying principles in biology and implementing them in biomimetic technical applications might be a major contribution towards developing functional adaptive, resource- and energy-efficient applications including materials, structures and components that are safe for humans and the environment.

Standardization in this area can play an important role towards disseminating biomimetics for sustainable technical development. The ISO/TC 266 members are working towards the implementation of standards in biomimetics to push the topic and prepare for the next technological leap which should lead to wide acceptance of the methods discussed in the standards.

## **4 REPRESENTATION AND PARTICIPATION IN THE ISO/TC**

### **4.1 [Countries/ISO member bodies that are P and O members of the ISO committee](#)**

#### **4.2 Analysis of the participation**

Membership of TC 266 includes countries and representatives from Europe, Asia and Middle East, North America and South America. The committee will take steps to encourage additional members.

## **5 OBJECTIVES OF THE ISO/TC AND STRATEGIES FOR THEIR ACHIEVEMENT**

### **5.1 Defined objectives of the ISO/TC**

Biomimetics include various scientific/technological disciplines. Therefore it is necessary to connect these fields with an independent Technical Committee in ISO. It is reasonable to start international standardization at an early stage – when the industrial demand expands and worldwide research and development increases. It can be assumed that global interdisciplinary cooperation will be fostered and smoothed by having international standards at an early stage of biomimetic developments.

The first objective of the ISO/TC is the development of an International Standard regarding terminology and the differentiation between biomimetics and conventional products and processes. This aim is achieved with the development of ISO 18458. A future task would be to divide ISO 18458 into a terminology part and a methodology part and to refine the content.

Parallel to the work on terminology the ISO/TC will develop further International Standards. The most promising approaches for the use of developers, designers, engineers, technical and natural scientists are standards concerning advanced materials and biomimetic optimization:

International Standards regarding biomimetic methods, structures and materials will be developed describing the transfer of biological principles into technical applications. A first standard has already been developed (ISO 18457).

International Standards including biomimetic optimization, evolutionary algorithms and biomimetic information processing will be developed concurrently. A first document on biomimetic structural optimization has been developed (ISO 18459).

An additional task would be to develop a biomimetic assessment framework.

### **5.2 Identified strategies to achieve the ISO/TC's defined objectives**

National Guidelines can be used as a basis for the development of International Standards.

To ensure efficient work of the ISO/TC the following structure was set up.

**CAG: Chair Advisory Group**

**WG 1: Terminology and methodology**

**WG 2: Structures and materials**

**WG 3: Biomimetic optimization**

**WG 4: Knowledge infrastructure of biomimetics**

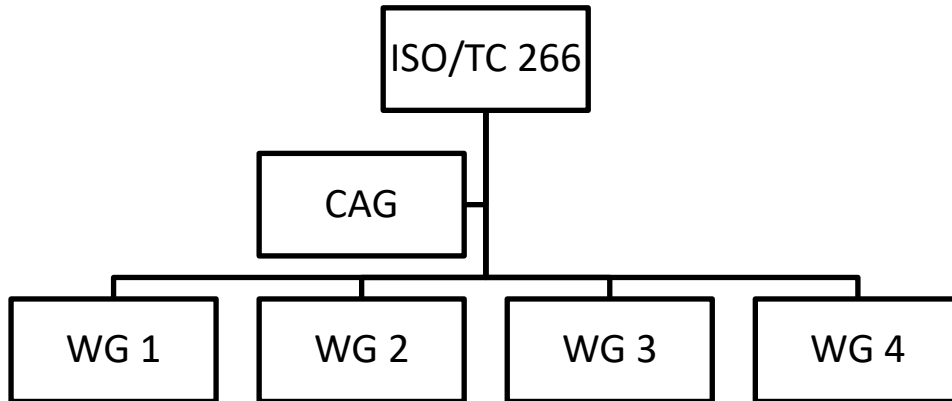

Liaisons are established with relevant international initiatives and stakeholders. International initiatives provide a forum for information, discussion and collaboration for its members and the scientific community, acting together in regional and international projects, organizations and institutions.

The following Liaisons are established with ISO/TCs and one CEN/TC:

ISO/TC 150	Implants for surgery
ISO/TC 207	Environmental management
ISO/TC 229	Nanotechnologies
ISO/TC 279	Innovation management
CEN/TC 350	Sustainability of construction works

## **6 FACTORS AFFECTING DELIVERY AND IMPLEMENTATION OF THE ISO/TC WORK PROGRAMME**

One key factor for the successful development and implementation of International Standards is the involvement of leading experts from the academic world and especially from the industrial sector. None of the key positions in the ISO/TC are vacant. Nevertheless, further member bodies (countries) should be included into the work.

No legal or regulatory issues are known today which may influence the outcome of the activities of this ISO/TC.

In order to reflect the society's needs properly the standardization process has to be transparent. Japan started to publish newsletter from Japanese Industrial Standards Committee (JISC) and deliver to all of the stakeholders for this purpose. This should help reduce the risk of non-acceptance of the results of the ISO/TC.

## **7 STRUCTURE, CURRENT PROJECTS AND PUBLICATIONS OF THE ISO/TC**

This section gives an overview of the ISO/TC's structure, scopes of the ISO/TCs and any existing subcommittees and information on existing and planned standardization projects, publication of the ISO/TC and its subcommittees.

7.1 [Structure of the ISO committee](#)

7.2 [Current projects of the ISO technical committee and its subcommittees](#)

7.3 [Publications of the ISO technical committee and its subcommittees](#)

## Reference information

[Glossary of terms and abbreviations used in ISO/TC Business Plans](#)

[General information on the principles of ISO's technical work](#)