

EXECUTIVE SUMMARY

A set of International Standards for a wide selection of vital oil & gas industry materials, equipment and offshore structures is emerging from the International Standards Organization, ISO. These standards are primarily the responsibility of ISO Technical Committee 67 (ISO TC67). They are developed using a consensus process that includes more than 1500 oil & gas industry experts from around the globe and an international review and approval process.

145 ISO standards have now been issued, including 21 revisions or new publications in 2009. A further 23 are planned for revision or new publication this year. The international oil and gas industry and national standardisation

organisations support these standards for worldwide applications. North and South American, Chinese, European, Gulf states, Russian and other standards bodies are now adopting them for regional and national use.

For industry, they will reduce costs and delivery time, and facilitate trade across national borders. For regulators, they offer support for goal-setting and functional regulations, while achieving higher levels of safety through better design. These standards are now being implemented widely in oil and gas provinces around the world, replacing existing industry, regional and national standards and eliminating or reducing the need for company-specific specifications. For details on standards available from ISO TC67, See the wall-chart inside.



<http://info.ogp.org.uk/standards/>

REGULATORS' USE OF STANDARDS

OGP Report No. 426 on "Regulators' use of standards", published March 2010, reflects the current situation of fourteen national regulators' around the globe reference and use of national, regional, international and industry standards in their regulatory documents, with a particular focus on standards for materials, equipment, systems and structures for the offshore petroleum industry. This report attempts to analyze the documents prepared by national and provincial lawmakers and the regulators themselves.

Regulators make good use of standards. 1348 references in total have been identified,

whereas 1140 of these are to different, individual standard titles. Of these 1140, as many as 989 or 87% are referenced by one regulator only. This shows a wide spread in regulators' references. This leaves only 13% of the standards to be referenced by two or more regulators. These standards emanate from more than 60 different standards organisations around the globe.

Compared with an earlier European analysis performed in 1996, there is a significant increase in the reference to international standards and a sharp decrease in references to national standards. Considering European regulators only, the new analysis compared

continued overleaf...



RUSSIAN ISO WORK

One of the most progressive Russian committees is the TC 23 on "Technique and technologies of oil and gas producing and refining". In 2008 eleven national standards were developed in TC 23, on the basis of ISO standards. In 2009 seven international standards have been included in the plan of national standardization. By the end of 2010 harmonization of seventeen international and other standards are planned. The following standards are authorized now: GOST R 53683:2009 (ISO 13535:2000) Drilling hoisting equipment, GOST R 53682:2009 (ISO 13705:2006) Fired heaters, GOST R ISO 13707:2009 Reciprocating compressors, GOST R 53680:2009 (ISO 14693:2003) Drilling equipment, GOST R ISO 15547-1:2009 Heat exchangers, GOST R 53677:2009 (ISO 16812:2007) Shell & tube heat exchangers.

ISO TC67
goes to Doha,
Qatar for its
plenary meeting, 26-
27 October 2010



Countries covered in the report

ISO Standards for use in

ISO 10418 Basic surface safety systems
 ISO 10423 Wellhead & christmas tree equipment (Rev)
 ISO 13533 Drill-through equipment (BOPs)
 ISO 13534 Hoisting equipment - care/maint (Rev)
 ISO 13535 Hoisting equipment - specification (Rev)
 ISO 13626 Drilling and well-servicing structures
 ISO 13702 Control & mitigation of fire & explosion
 ISO 13703 Offshore piping systems
 ISO 14224 Reliability/maintenance data
 ISO 14692 GRP piping, Parts 1-4
 ISO 14693 Drilling equipment

ISO 15156-1 Selection of cracking resistant materials for use in H₂S environments (Rev)
 ISO 15156-2 Cracking-resistant steels and cast irons for use in H₂S environments (Rev)
 ISO 15156-3 Cracking-resistant alloys for use in H₂S environments (Rev)
 ISO 15138 HVAC
 ISO 15544 Emergency response (Amd)
 ISO 15663 Life cycle costing, Parts 1-3
 ISO 17776 Assessment of hazardous situations
 ISO 20815 Production assurance and reliability management
 ISO 21457 Materials selection (New)
 ISO/TS 27469 Method of test for offshore fire dampers (New)
 ISO/TS 29001 Sector-specific quality management systems (Rev)

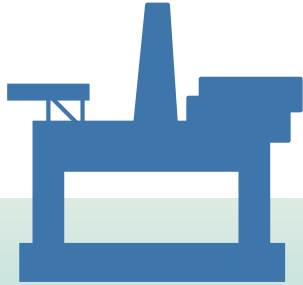

ISO 13624-1 Marine drilling riser systems (New)
 ISO/TR 13624-2 Marine drilling riser system analysis (New)
 ISO 13625 Marine drilling riser couplings
 ISO 19901-7 Station-keeping systems for floating offshore structures (Rev)
 ISO 19904-1 Floating offshore structures

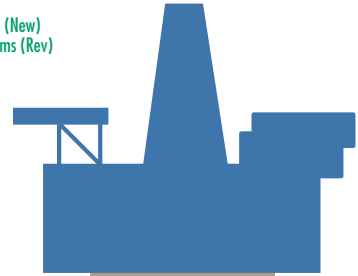

ISO 19900 Offshore safety management systems (Rev)
 ISO 19901-1 Measurement of wellbore integrity
 ISO 19901-2 Measurement of wellbore integrity
 ISO 19901-3 Topography and geology
 ISO 19901-4 Geotechnical engineering
 ISO 19901-5 Wellhead and christmas tree equipment
 ISO 19901-6 Marine drilling riser systems
 ISO 19902 Fixtures and fittings
 ISO 19903 Fixtures and fittings
 ISO 19906 Arc flash hazard analysis

ISO 13628-1 Subsea production systems (Amd)
 ISO 13628-2 Subsea flexible pipe systems
 ISO 13628-3 Subsea TFL pumpdown systems
 ISO 13628-4 Subsea wellhead and tree equipment (Rev)
 ISO 13628-5 Subsea control umbilicals (Rev)
 ISO 13628-6 Subsea production controls

ISO 13628-7 Completion/workover riser system
 ISO 13628-8 ROV interfaces
 ISO 13628-9 ROT intervention systems
 ISO 13628-10 Bonded flexible pipe
 ISO 13628-11 Flexible pipe systems for subsea and marine applications

ISO/TR 10400 Calculations for OCTG performance properties
 ISO 10405 Care/use of casing/tubing
 ISO 10407-1 Drill stem design
 ISO 10407-2 Inspection and classification of drill stem elements
 ISO 10414-1 Field testing of water-based fluids
 ISO 10414-2 Field testing of oil-based fluids
 ISO 10416 Drilling fluids - lab testing
 ISO 10417 Subsurface safety valve systems
 ISO 10424-1 Rotary drill stem elements

ISO 10424-2 Threading and gauging of connections
 ISO 10426-1 Well cementing (Rev)
 ISO 10426-2 Testing of well cements (Rev)
 ISO 10426-3 Testing of deepwater well cement
 ISO 10426-4 Preparation and testing of atmospheric foamed cement slurries
 ISO 10426-5 Shrinkage and expansion of well cement
 ISO 10426-6 Static gel strength of cement formulations
 ISO 10427-1 Bow spring casing centralizers

ISO 10427-2 Centralizer placement and stop
 ISO 10427-3 Performance testing of cement
 ISO 10432 Subsurface safety valves
 ISO 11960 Casing and tubing (Rev)
 ISO 11961 Drill pipe
 ISO 13500 Drilling fluids (Amd)
 ISO 13501 Drilling fluids - processing systems
 ISO 13503-1 Measurement of viscous properties
 ISO 13503-2 Measurement of properties of heavy brines
 ISO 13503-3 Testing of heavy brines
 ISO 13503-4 Measurement of stimulation & fracture conductivity
 ISO 13503-5 Measurement of long term corrosion
 ISO 13678 Thread compounds (Rev)
 ISO 13679 Connection testing (Rev)
 ISO 13680 CRA seamless tubes for casing

with 1996 analysis shows an increase from 16 to 38% reference to international standards and a decrease from 39 to 14% reference to national standards.

API standards are dominating, with 225 references, including 49 API Manual of Petroleum Measurement (MPMS) standards. ISO has delivered 152 of the standards referenced by the regulators covered by this report and 59 of these come from the work of ISO/TC 67. Referenced standards appear to be voluntary in most of the regulatory regimes, in the sense that other technical solutions can be opted for provided proof of compliance can be documented.

Capture the value added

Make use of well over 145 new ISO standards for your own benefit!

The main conclusions based on these findings can be summarised as follows: This report shows clearly that standards play an important role in the regulators technical definition of the safety level of oil and gas installations they regulate. In fact, the oil and gas industry and regulators cannot work effectively without using these standards. The diversity of references provides a challenge for international operators in understanding and applying correctly all of these different references for the actual E&P activities in different countries. Download OGP's report from <http://www.ogp.org.uk/pubs/426.pdf>.

ISO STANDARDS ON PIPELINE COATINGS

Until now, the existence of different standards throughout the world for external pipeline coatings has posed problems for suppliers, manufacturers and end users. Solutions are now available with the recent publications of three standards that were developed by the ISO/TC67/SC2:

- ISO 21809-1: Polyolefin coatings (3 layer) – publication pending
- ISO 21809-2, -3 and -4 published
- ISO 21809-5: External concrete coatings – publication due first half of 2010

Each of these standards will provide in a single document a consistent and unified approach to requirements for these pipeline coating systems worldwide. The standards

n the oil & gas industry

ISO 3977-5 Gas turbines – procurement
ISO 10428 Sucker rods
ISO 10431 Pumping unites
ISO 10434 Bolted bonnet steel gate valves
ISO 10437 **Special-purpose steam turbines (Rev)**
ISO 10438 Lubrication, shaft-sealing and control-oil systems, Parts 1-4
ISO 10439 Centrifugal compressors
ISO 10440-1 Rotary-type positive-displacement process compressors (oil-free)
ISO 10440-2 Rotary PD packaged air compressors
ISO 10441 Flexible couplings – special
ISO 10442 Integrally geared air compressors
ISO 13631 Reciprocating gas compressors
ISO 13691 High speed enclosed gear units
ISO 13704 Calculation of heater tube thickness
ISO 13705 Fired heaters for general service
ISO 13706 Air-cooled heat exchangers
ISO 13707 Reciprocating compressors
ISO 13709 **Centrifugal pumps (Rev)**

ISO 13710 Reciprocating positive displacement pumps
ISO 14691 Flexible couplings – general
ISO 15547-1 Plate & frame type heat exchangers
ISO 15547-2 Braze aluminium platefin type heat exchangers
ISO 15649 Piping
ISO 15761 Steel valves DN 100 and smaller
ISO 16812 Shell & tube heat exchangers
ISO 17292 Metal ball valves
ISO 21049 Centrifugal and rotary pumps shaft sealing
ISO 23251 Pressure-relieving and depressuring systems
ISO 23936-1 **Thermoplastics (New)**
ISO/TS 24817 Composite repair of pipework
ISO 25457 Flares details
ISO 28300 Venting of storage tanks
ISO 28460 **LNG - Ship to shore interface (New)**

shore structures - general requirements
ocean design and operating considerations
ismic design

ides structure (New)
otechnical and foundation design
ight control
rine operations (New)
ed steel offshore structures
ed concrete offshore structures
ic offshore structures (New)

p-collar testing
t float equipment

ems evaluation
eries of completion fluids
roppants (Amd)

gravelpack fluid leakoff
ductivity of proppants

and tubing

ISO 14310 Packers and bridge plugs
ISO 15136-1 Progressing cavity pump systems (Rev)
ISO 15136-2 Progressing cavity pump systems - drive heads
ISO 15463 Field inspection of new casing, tubing and plain end drill pipe
ISO 15546 Aluminium alloy drill pipe
ISO 16070 Lock mandrels and landing nipples
ISO 17078-1 Side-pocket mandrels (Amd)
ISO 17078-2 Flow control devices for side-pocket mandrels (Amd)
ISO 17078-3 Latches & seals for side-pocket mandrels & flow control devices (New)
ISO 17078-4 Side-pocket mandrels and related equipment (New)
ISO 17824 Sand control screens (New)
ISO 28781 Subsurface tubing mounted formation barriers (New)

ISO 3183 Steel pipe for pipeline transportation systems
ISO/TS 12747 Pipeline life extension (New)
ISO 13623 Pipeline transportation systems (Rev)
ISO 13847 Pipeline welding
ISO 14313 Pipeline valves
ISO 14723 Subsea pipeline valves (Rev)
ISO 15589-1 Cathodic protection for on-land pipelines
ISO 15589-2 Cathodic protection for offshore pipelines
ISO 15590-1 Pipeline induction bends (Rev)
ISO 15590-2 Pipeline fittings
ISO 15590-3 Pipeline flanges
ISO 16708 Pipeline reliability-based limit state design
ISO 21329 Test procedures for pipeline mechanical connectors
ISO 21809-2 Fusion-bonded epoxy coatings
ISO 21809-3 Field joint coatings for pipelines (Amd)
ISO 21809-4 Polyethylene coatings (2-layer PE) (New)
ISO 21809-5 External concrete coatings (New)



Standards in **brown** issued in 2009

Standards in **green** are a priority for 2010 issue

These ISO standards are only a core collection of several hundreds of International Standards available for the oil & gas industry

specify in detail the requirements for the qualification, application, testing and handling of the coatings applied for the external corrosion protection of bare steel pipe for use in pipeline transportation systems in the petroleum and natural gas industries. They will facilitate the educated purchasing, specification, manufacturing and application of these coatings in the international market place. These ISO standards will cut costs and complications for petroleum and natural gas sectors.



ISO 10423 WELLHEADS & CHRISTMAS TREES REVISED

December 2009 saw the release of the 4th edition of this key ISO standard 10423 for Wellheads and Christmas trees. This complex standard has been updated to the needs of the industry today. For example, it includes now a wider references to International Standards for e.g. NDE techniques. ISO 15156 (NACE MR 0175) has now been implemented for sour service material requirements. Many more changes have been made that are relevant to manufacturers and end-users. Implementation of this latest revision offers more flexibility without compromising safety. API voted at their winter meeting in February to issue an adopt-back ballot for the new issue of ISO 10423 as API 6A 20th edition.

SUCCESS STORY – ADOPTION PROGRESS

API have now (February 2010) re-adopted some 76 of the ISO standards shown above. CEN adoptions are at some 132. GSO has adopted around 62 ISO standards shown above. These numbers represent growing consensus in the oil & gas industry around the globe. With Brazil, Canada, China, Kazakhstan, Russia and others adopting the same ISO standards, we are progressing towards the vision:

Global standards used locally worldwide

ISO STANDARDISATION OF IMPROVED BOLTED JOINT TECHNOLOGY

ISO 27509, Petroleum and natural gas industries – Compact flanged connections is in development in ISO/TC 67/SC6 based on NORSOK standard L-005, which was launched first time in 2003 for the Norwegian oil and gas industry.

The Compact Flange Connection (CFC) was developed for demanding applications such as in dynamic pipeline risers offshore, by VECTOR AS (former SPO) in Drammen, Norway, 20 years ago.

As opposed to commonly used flange connections with a relatively soft gasket or a metal seal ring transferring all bolt load between the flanges, which are found in ISO 7005 and ASME B16.5 etc, the CFC transfer all bolt load through metal to metal contact between the flange faces. A radially self energized and also pressure energized metal seal ring is used as the sealing member. The CFC is typically leak tight and static

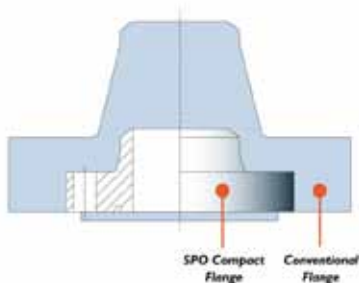

with no changes of bolt or sealing loads through any combination of internal pressure and external loads corresponding with the ultimate strength of the adjoining pipe.

The CFC technology was released for standardization in 1999 when an agreement was signed between SPO and the Norwegian oil companies Statoil and Norsk Hydro. Since large weight and space savings are obtained by using CFC, this technology has been widely used in process piping for high pressure oil and gas in Norway. The CFC dimensions are easily adapted to standard valve used in the oil and gas industry such as ISO 14313 and ASME B16.34.

The CFC technology can be found today in oil and gas service in subsea pipelines and production units, dynamic pipeline risers, process piping onshore and on

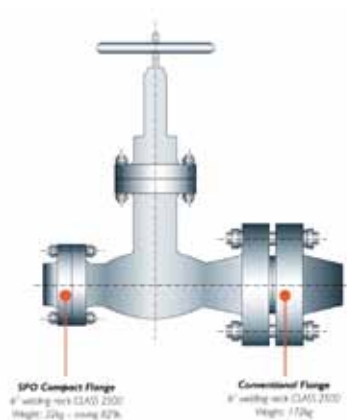

fixed and floating plants offshore. More than 100,000 CFCs are in operation in Norway, UK, Brazil, USA (Gulf of Mexico), West Africa, Australia and New Zealand.

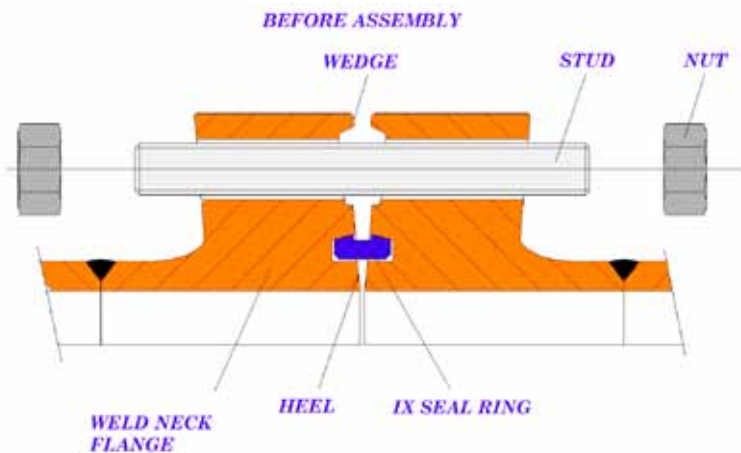

ABOUT OGP

The International Association of Oil & Gas producers (OGP) encompasses most of the world's leading publicly traded, private and state-owned oil & gas companies, oil & gas associations and major upstream service companies. OGP members operate in more than 80 different countries and produce more than half the world's oil and about one third of its gas.

The association was formed in 1974 to develop effective communications between the upstream industry and an increasingly complex network of international regulators.

An essential part of OGP's mission is to represent the interests of the upstream industry to international regulators and legislators.

OGP also helps members achieve continuous improvement in safety, health and environmental performance, and in the engineering and operation of upstream ventures. OGP's extensive international membership brings with it a wealth of know-how, data and experience. OGP committees and task forces manage the exchange and dissemination of this knowledge. OGP additionally promotes awareness of Corporate Responsibility issues such as transparency of revenues and combatting corruption.

The OGP Standards Committee monitors, co-ordinates and influences the development of International Standards to meet the needs of OGP members. There is close communication with national, regional and International Standards bodies, particularly the API, CEN and ISO. Information on the activities of the OGP Standards Committee and other OGP committees, including freely downloadable publications produced by the OGP, can be accessed via the OGP website at www.ogp.org.uk.

THE INTERNATIONAL STANDARDS BULLETIN

This bulletin is developed by the OGP Standards Committee, which includes members from: Addax, API, BP, CEN, ConocoPhillips, China Petroleum Standards Committee (CPSC), Eni, Energy Institute, ExxonMobil, Gazprom, Inpex, ISO, Kuwait Oil, Marathon, Maersk, NIOC, OMV, Pemex, Petrobras, Petro-Canada, PETRONAS, Petropars, Qatar Petroleum, Repsol-YPF, Saudi Aramco, Shell, Statoil, Total & Woodside.

<http://info.ogp.org.uk/standards>

OGP POSITION ON STANDARDS

OGP has been a catalyst in the industry's approach to standards and strongly supports the internationalisation of key standards used by the petroleum and natural gas industries.

OGP's position on standards is to:

- promote development and use of ISO and IEC International Standards;
- ensure standards are simple and fit for purpose;
- use International Standards without modification wherever possible;
- ensure visibility of the international standard's identification number, whatever the method of publication;
- base development of standards on a consensus of need;
- avoid duplication of effort;
- minimise company specifications which should be written, where possible, as functional requirements; and
- promote "users" on standards work groups.

The adoption of this approach is expected to minimise technical barriers to trade, enable more efficient worldwide operations, and improve the technical integrity of equipment, materials, and offshore structures used by the petroleum and natural gas industries.